

Fitting Instructions #3126IS

Audi A4, S4, A6, S6, A8, S8 / Volkswagen Passat, Santana Front Upper Control Arms Bushing



Note: Polyurethane bushings must be fitted to both sides of the vehicle. This kit should be installed by a Qualified Motor Mechanic.

- With the vehicle on jack stands/hoist, remove the wheels and remove the upper control arms. The complete strut upper aluminium bracket may need to be removed (access bolts from inside the engine bay) for easy removal of the control arm bolts. Note – these control arm bolts may be fitted from the opposite direction for easier servicing in the future;
- Remove the two inner bushes from the control arms by pressing them out - a hydraulic press and suitable press tools;
- Install the new bushings into the alloy arms so that an even amount of shell is protruding at each side;
- Using the grease supplied, liberally apply to the polyurethane bore of the bush, the outside of the metal crush-tube, and then push the tube into the bush;
- When installing #3127K for camber decrease, position the offset hole in the arm in the direction of the outer ball joints (as shown in the picture above);
- This kit will provide a fixed camber decrease/increase of a 0.5 degrees per side;
- Refit the control arms to the vehicle, tighten all bolts to the manufacturers torque specifications and carry out a wheel alignment.

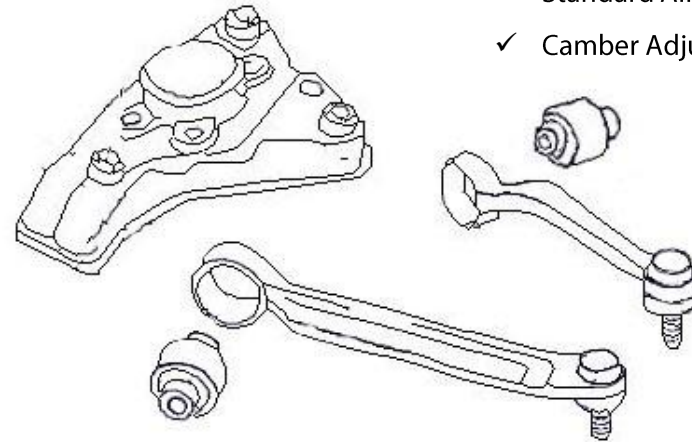

- ✓ Standard Alignment kit #3126K
- ✓ Camber Adjustment kit #3127K

