

# Fitting Instructions #3111IS

Mitsubishi Outlander / Mitsubishi Lancer

***Front Lower Control Arm Inner Rear Bushing (To Suit Right-Hand Drive Vehicles)***

**Note:** Polyurethane bushings must be fitted to both sides of the vehicle.

- Wheel-align the vehicle before the job is started and note settings;
  - With the vehicle on jack stands/hoist remove the front wheels and remove the lower control arms;
  - Remove original shell part from the housing with the use of a hydraulic press and suitable pressing tools, take care to prevent stretching arm;
  - With reference to the diagrams and the settings required, align the bushing with the bracket so that the hole in the bush is positioned to give the desired result.
  - Press the bushes into the housings;
  - The crush tubes can now be fitted to the bushes. A generous amount of the white grease supplied must be applied to both the bore of the bush and the outside of the crush tube.
- Fit the spacers supplied over the crush tubes top and bottom, use the white grease supplied to lubricate the spacers;
  - Refit the control arms;
  - Wheel-align vehicle and check new settings;
  - All mounting bolts are to be torqued to manufactures specifications.

Left hand side shown

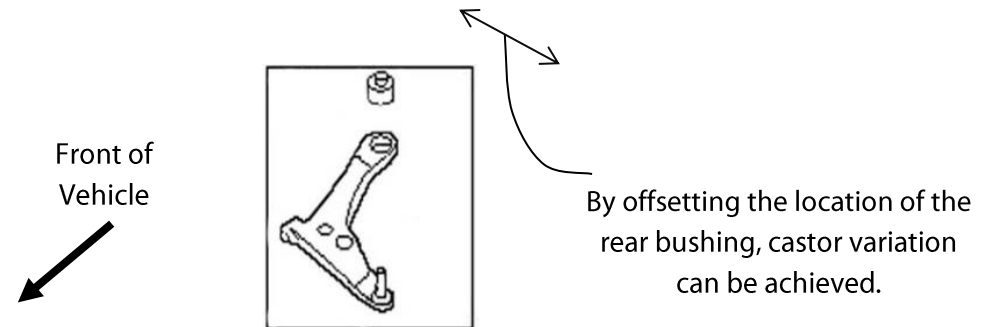

# Fitting Instructions #3111S

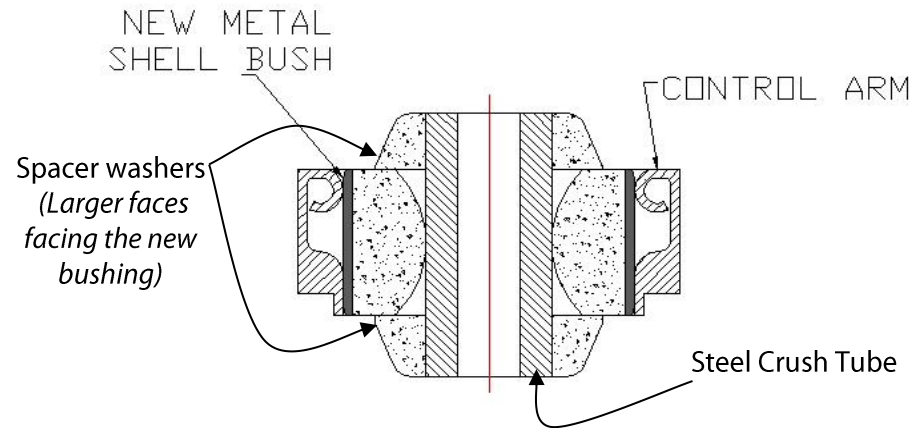

**Note** the orientation of the Spacer Washers.

As viewed from the top of the control arm.

**Kit #3170K** – Standard Replacement. No castor change.

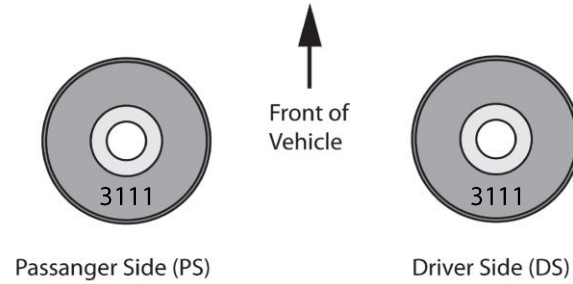

**Kit #3171K** – To counteract a slight pull to the left  
Single Offset, Passanger side castor increase (+0.5 degree).

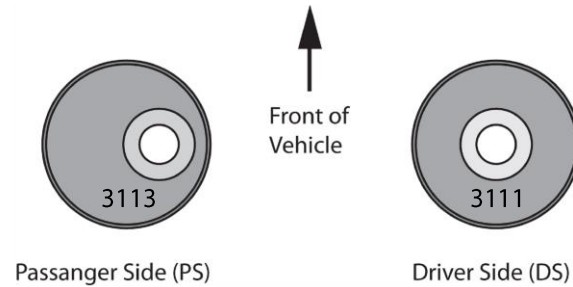

**Kit #3172K** – To counteract a strong pull left  
Double Offset, passanger +0.5 degree and driver -0.5 degree castor.

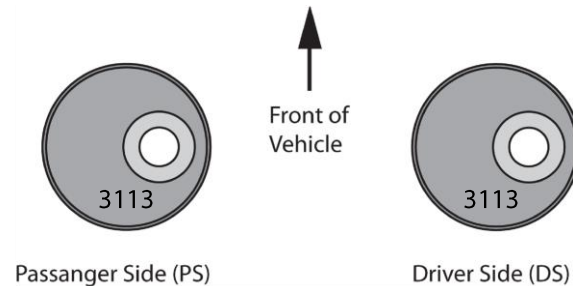

**Table 1:** Illustration of Castor Settings